

Part number

# MHP 10.20



## Brief description:

surface mounting housings with 2 levers, size "57.27", M20, metal version, IP66

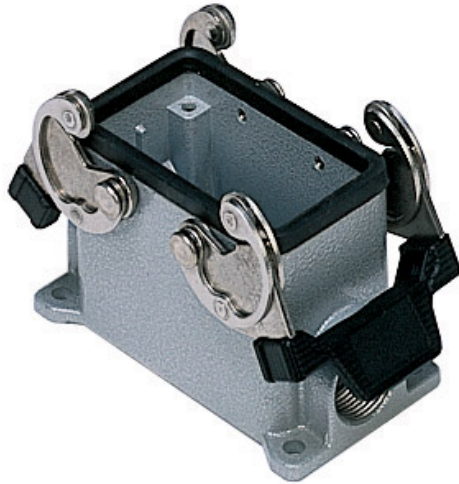

Product description		Approvals / Standards	
Version	metal version	Quality mark	UL (type:4/4X/12),  , EAC
Series	surface mounting housings with 2 levers	Conformity	CQC, CE
Product type	with 2 levers	General ordering information	
Family	CLASS enclosures	EAN13 code	8015747054331
Size	size "57.27"	Tariff number	85369095
Technical data		Packaging Information	
Material	metal	Packaging length	475,00 mm
IP degree of protection	IP66 (and IP69K DIN 40050 - 9)	Packaging height	170,00 mm
Cable entry	M20	Packaging width	150,00 mm
Further technical details		Packaging weight	3,93 kg
Weight	297,00 g	Packaging volume	12,11 dm <sup>3</sup>
		Packaging description	Carton box
		Packaging quantity	10 Pcs
		Packaging EAN code	8015747251372
		Sub-packaging weight	1,97 kg
		Sub-packaging description	Plastic packaging
		Sub-packaging quantity	5 Pcs
		Sub-packaging EAN barcode	8015747054355

Part number

# MHP 10.20



Catalogue drawings

## CHP CAP - MHP MAP

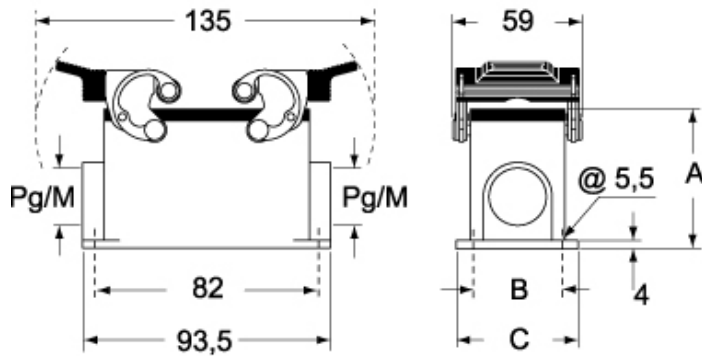

## CHP CS/CP CAP CS/CP - MHP CS/CP MAP CS/CP

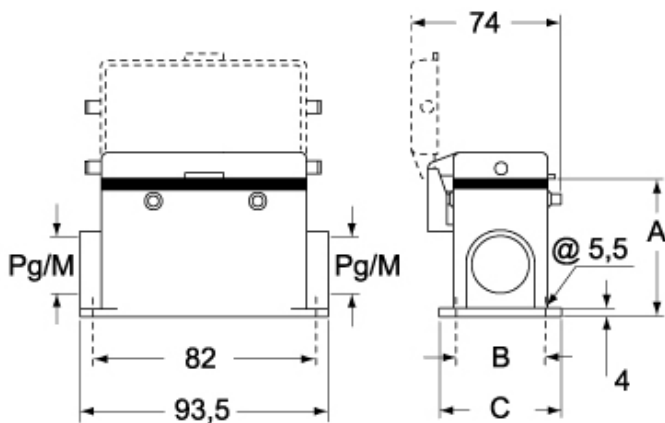

	A	B	C
CHP L / MHP L	57	40	52
CAP L / MAP L	73	45	57
CHP CS / MHP CS	57	40	52
CAP CS / MAP CS	73	45	57
CHP CP / MHP CP	57	40	52
CAP CP / MAP CP	73	45	57